

THIS DOCUMENT AND THE SUBJECT MATTER CONTAINED THEREIN IS PROPRIETARY AND IS NOT TO BE USED OR REPRODUCED WITHOUT PRIOR WRITTEN APPROVAL.

COPYRIGHT ©2007 PRIME DESIGN SYSTEMS, INC.

DATE PLOTTED: 01/26/2007 TIME PLOTTED: 07:54:55

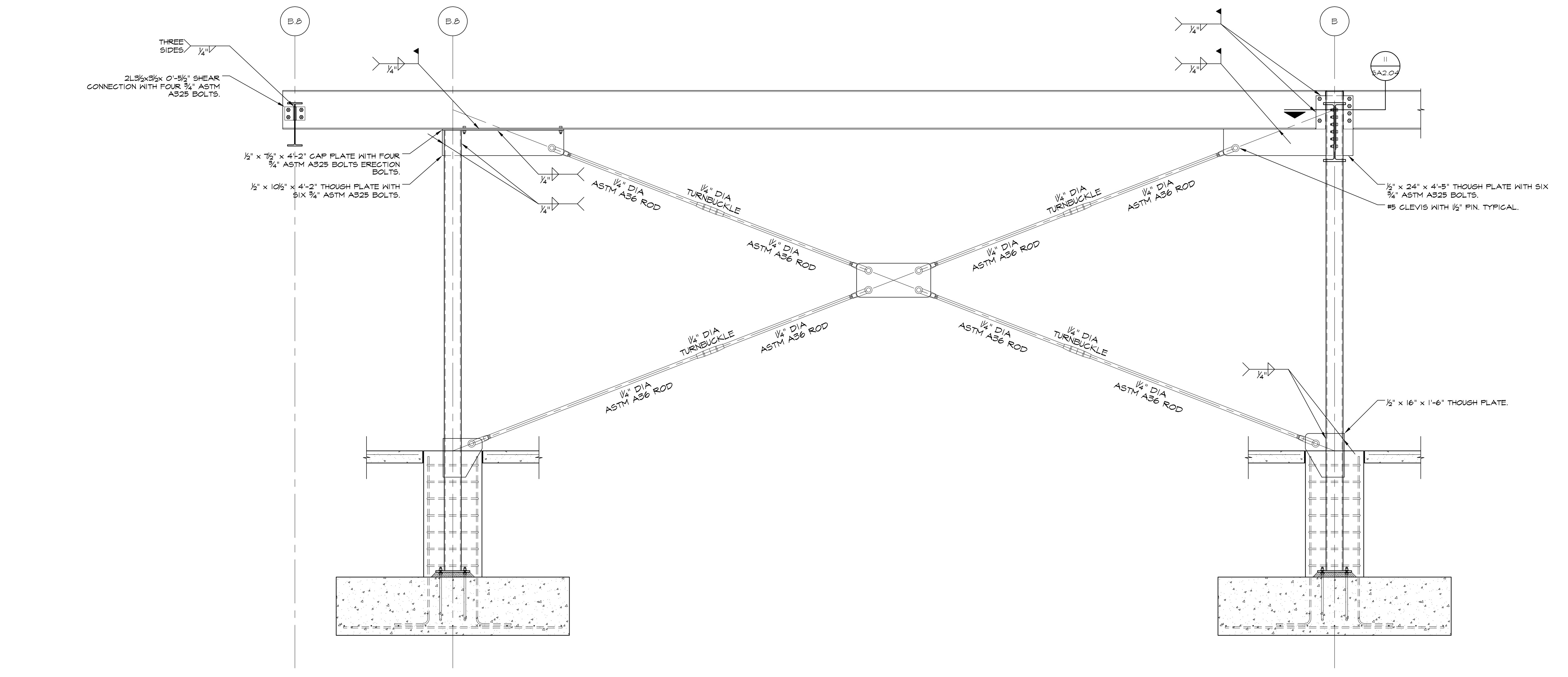

4 Section
SCALE: 1/2" = 1'-0"

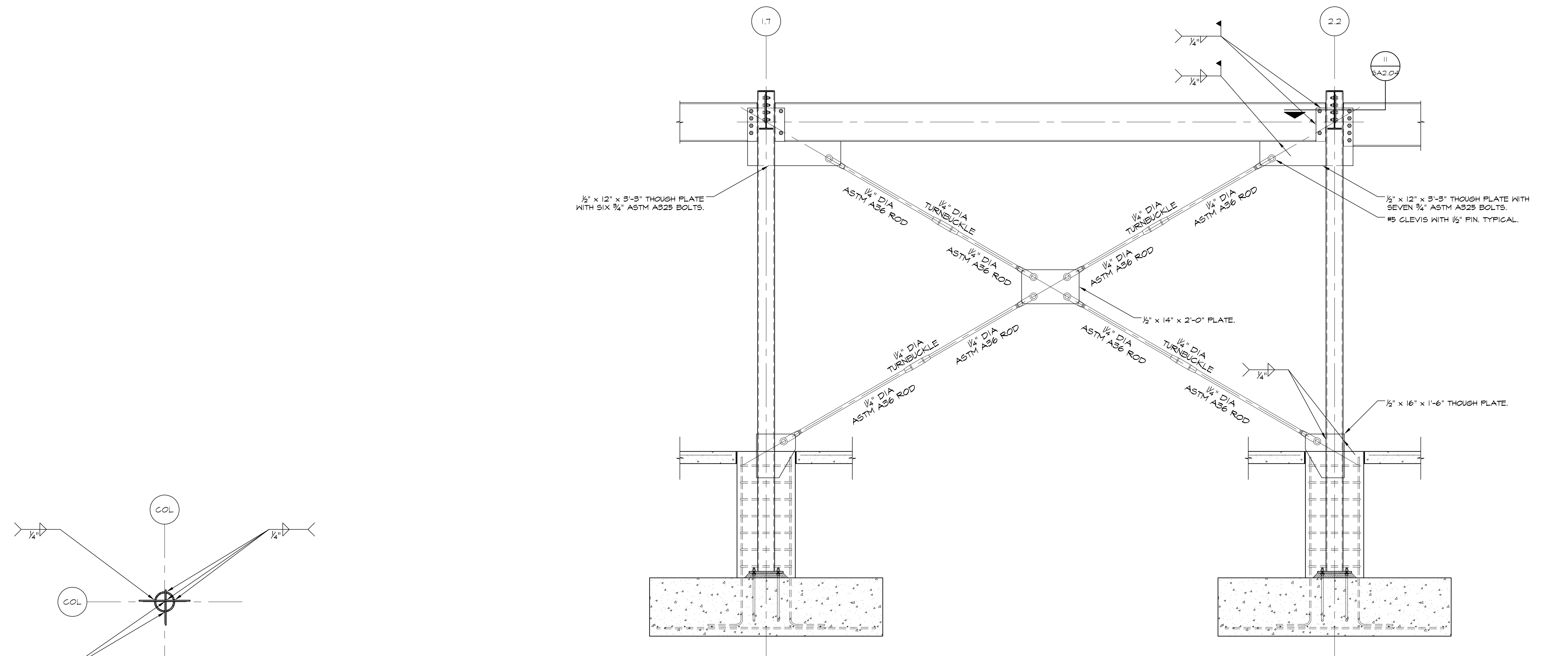

1 Section
SCALE: 1/2" = 1'-0"

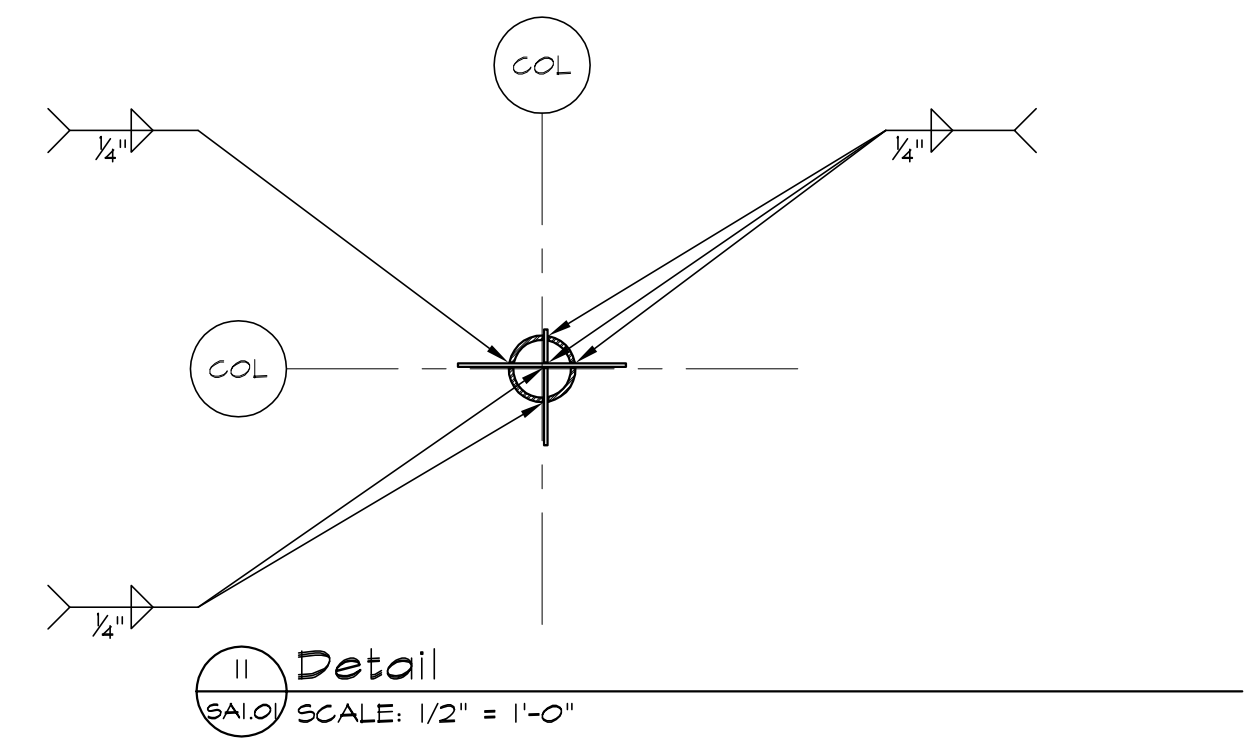

II Detail
SCALE: 1/2" = 1'-0"